

This drawing is the property of ITAB Shop Products and shall be returned to us upon request. It may not be used to harm the interests of ITAB Shop Products.

ALL MATERIAL MUST BE RoHS COMPLIANT

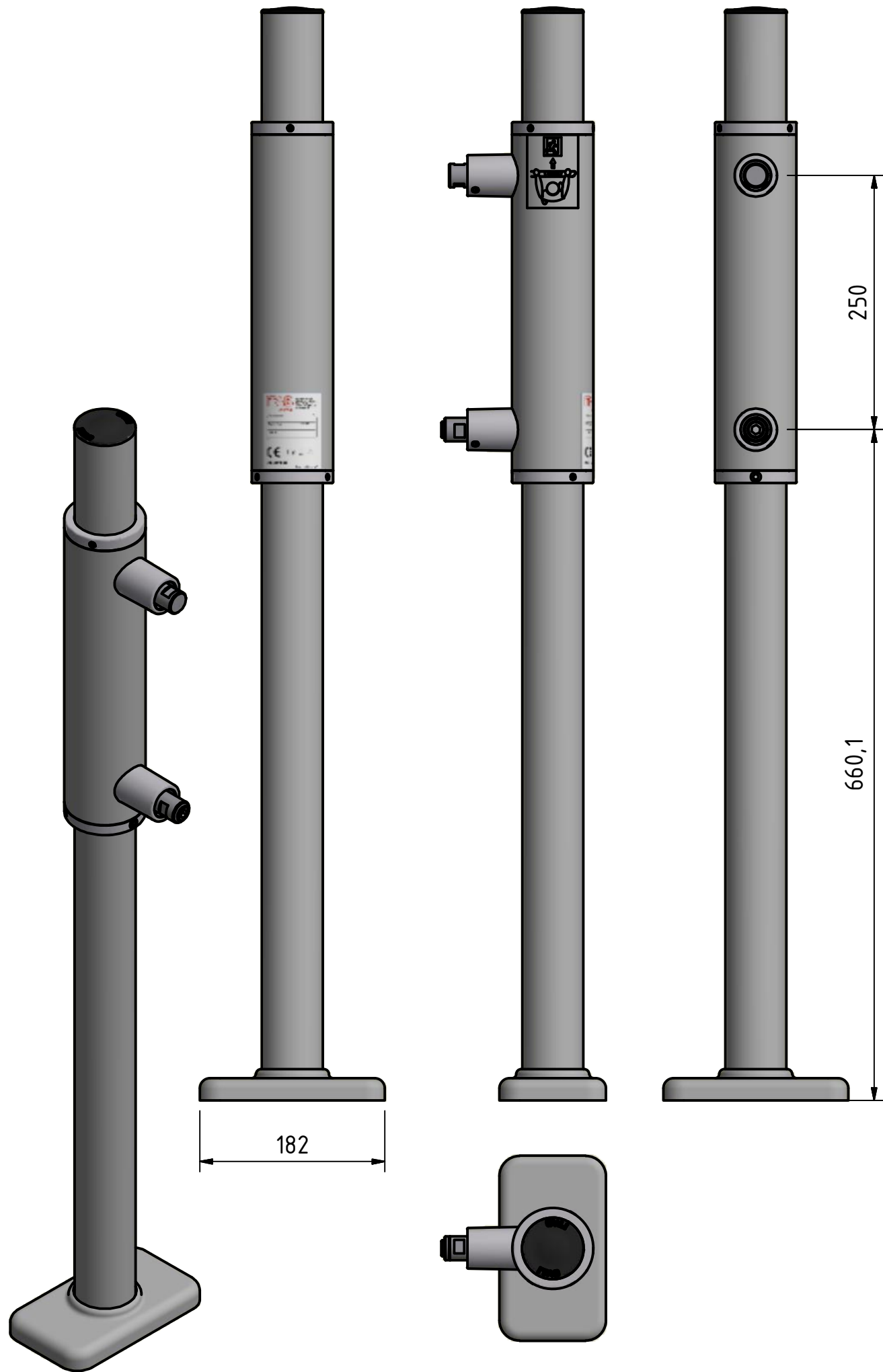

Left (1 : 2)

Nr	Ändring	Datum	Inf.	Godk.
A	Component details have been changed	121009	mujo	
B	10856-80 been changed (+2 Flat springs, -3 Flat springs)	121220	mujo	
C	+29017-01, -10898-30 10853-80, 10856-80 has been changed	150304	mujo	
D	(+3 Flat springs, -2 Flat springs)	150826	mujo	
E	+27419-01,+ 10970-10	180504	mujo	

Nr	Variant	Surface	Quality	Datum
1	-10	Chrome	Ni/Cr 20 µm	111216
2	-20	Powder coating		120301
3	-80	Untreated		120301

27	1	Screw M6*50 DIN612	Galvanized Steel 8.8	29017-01
26	2	Popnut M6 UKO 30	Steel galvanized	28683-30
25	1	Product Label 77x60	Siverpolyester 7872EC Blank	27419-01
24	1	Label Cash Grind Panic 72x52	Polyester 7872	10970-10
23	1	Shims plate	Q235	10897-80
22	1	Supporting ring	Q235	10896
21	1	Shims	Q235	10895-80
20	1	Stop profile	EN 32	10856-80
19	1	Locating pin	SS1914	10855-30
18	2	Bearing Ø60.5xØ78x10		10854
17	3	Spring	SUS301H Spring Steel	10853-80
16	1	Spring holder lower part	Q235	10852-30
15	1	Spring holder upper part	SS 1914	10849-30
14	1	Supporting ring	Q235	10848
13	1	Tube weld		10845
12	1	Post weld		10843
11	2	Screw M6x14 DIN 7991	Steel 10.9 galvanized	10842-30
10	1	Compression spring Ø11xØ2.5x55	Ventilfjäders.	10836-80
9	1	Mounting pin	AISI 1113	10835-30
8	10	Screw M6x10 DIN 914	Steel 45H	10823-30
7	2	Gate fastener R40	Al Alloy 102	10804
6	1	Upright base cover Ø60	DC04 shiny surface Ra max=0.4µm	10268
5	1	Top cap Ø60 with logo	PE	10212
4	4	Screw M8x8 ribbed bottom DIN 916	Steel 45H	077031
3	1	Steel ball Ø12	AISI 1010-16	076032
2	1	Screw M16x2x16 DIN913	-	071214
1	1	Skruv MRX 6x12	-	051505

Item	Qty	Title	Material	Part number
Designer	Drawer	Approved	Where no tolerance is specified:	Scale
	169mure		SS-ISO 2768-m	1 : 5
				Replaces
Push gate Ø60 left				Replaced by
				Weight
				Date
				3/22/2012
				Dwg.no.
				10860
				E