



## VERSATILITY

OPL <> COIN

Standard models can be programmed as OPL or coin laundry version, central pay, etc.

SINGLE <> STACKED

Models can be stacked on top of a washer or on another dryer. Control panels can be assembled between both drums for better ergonomics. (Except HPDL Model)

Ideal for multiple solutions: hotels, hostels, campings, coin laundries, facility services (mops), gyms, etc.



## OUTSTANDING FEATURES

M PROGRAMMER: selection of time and temperature, user friendly and versatile (OPL or coin laundry version)

Reduced drying times (less than 45 minutes)

6,75 kw heating, option 4,5 kw (4,5 kw in Essential Model)



## EFFICIENCY

Optimised airflow

Wide fluff filter as drawer

Efficient design



## ROBUSTNESS

Outer casing in grey skinplate

(White lacquered in HPDL model)

Robust aluminium big door

Drawer as fluff filter (not in the door but as a specific drawer)

Industrial fan and powerful airflow

Sturdy construction of the dryer structure and panels



## OTHERS

Galvanized drum

FULL SCREEN FILTER: drawer fluff filter, not in the door.

**New gas heated models**

CE approved product



## OPTIONS

- Stainless steel outer casing (Except HPDL Model)
- AISI 304 stainless steel drum (Except HPDL Model)
- Reverse door opening (Except HPDL Model)
- Control panel in the bottom (stacked dryer - Except HPDL Model)
- Plinth for better ergonomics (Except HPDL Model)
- **Complete container order + compact packing**
- Maritime voltage 440V III 50/60 Hz No neutral
- Coin/token kit

TECHNICAL DATA	UNID.	HPD-8		HPD-10 // HPDL-10M	
<b>CAPACITY &amp; DRUM</b>					
Capacity 1:20	Kg	8		10	
Volume (litres)	l	160		200	
Drum diameter Ø	mm	590		590	
Drum depth	mm	585		690	
<b>DOOR</b>					
Height center door	mm	554		554	
Height base door	mm	320		320	
Door diameter	mm	480		480	
<b>GENERAL DETAILS</b>					
Electronic control	-	✓		✓	
USB connection	-	X		X	
Construction Panels	-	Skinplate		Skinplate / White lacquered	
Plinth OPT	-	opt		opt / NO	
Coin laundry version	-	✓		✓	
Noise level	dB	62		62	
<b>POWER</b>					
Motor / Fan	kW	0,37		0,37	
Electric heating	kW	6,75 / 4,5		6,75 / 4,5 // 4,5	
Gas heating	kW	6,70		6,70	
<b>CONNECTIONS</b>					
Tension 230V I+N+T 50Hz / 60Hz	N° x mm2/A	3 x 10 / 40A	3 x 1,5 / 10A	3 x 10 / 40A	3 x 1,5 / 10A
Tension 230V III+T 50Hz // 60Hz	N° x mm2/A	4 x 4 / 25A	3 x 1,5 / 10A	4 x 4 / 25A	3 x 1,5 / 10A
Tension 400V III+N+T 50Hz // 60Hz	N° x mm2/A	5 x 2,5 / 16A	3 x 1,5 / 10A	5 x 2,5 / 16A	3 x 1,5 / 10A
Fume exhaust Ø	mm	100		100	
Maximum airflow	m³/hour	300		300	
<b>CONSUMPTIONS</b>					
Electric heating consumption	kW	6,75 / 4,5		6,75 / 4,5	
Instant propane gas consumption (G31)	kg/h	0,57		0,57	
Instant natural gas consumption (G20)	m³/h	0,71		0,71	
<b>DIMENSIONS / PACKING DIMENSIONS</b>					
Net width / Gross width	mm	680 / 710		680 / 710	
Net Depth / Gross Depth	mm	722 / 832		775 / 832	
Net Height / Gross Height	mm	1056 / 1141		1056 / 1141	
Net weight / Gross weight	kg	89 / 101		93 / 104	

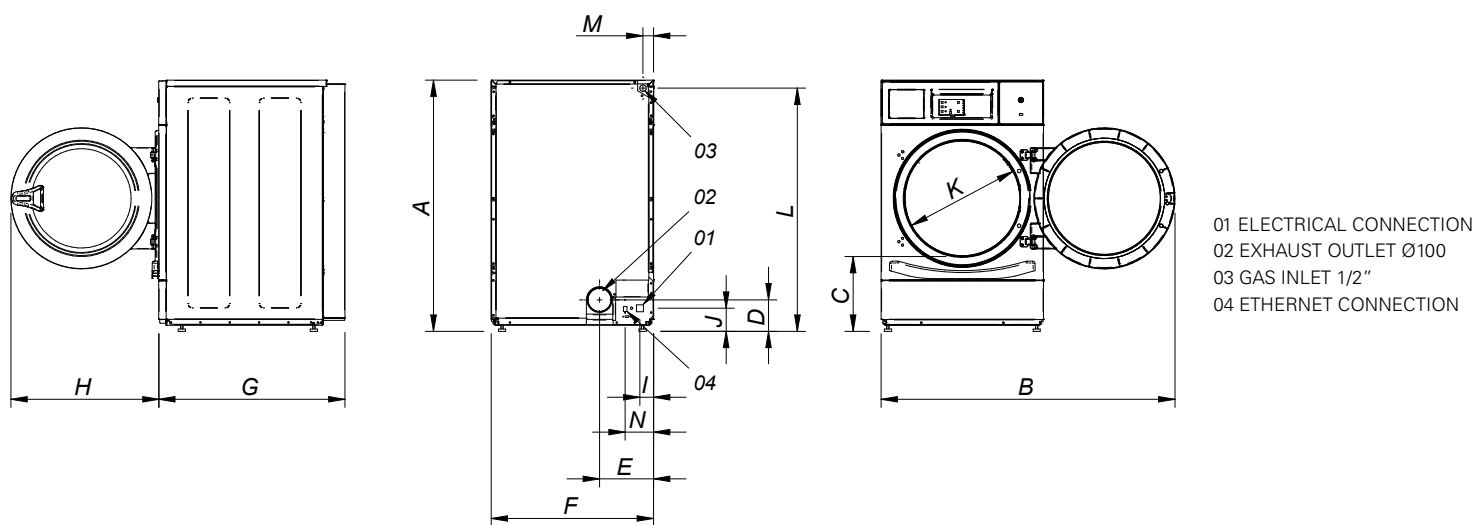

	A	B	C	D	E	F	G	H	I	J	K	L	M	N
HPD-8	1056	1227	320	140	226	680	722	615	57	91	480	1015	50	118
HPD-10	1056	1227	320	140	226	680	775	615	57	91	480	1015	50	118